

NO.	ISSUE DATE
	Permit 12/10/2020
1	Response to Comments 01/28/2021

Peaches and Cream 2020
 4525 Ferncroft Road
 Mercer Island
 Washington 98040

Construction Documents

6764 REGISTERED ARCHITECT

 ROBERT HARRISON
 STATE OF WASHINGTON

 HARRISON architects
 1133 18th Avenue, Suite B032
 Seattle, Washington 98122
 206.794.2738 mobile
 www.harrisonarchitects.com

Survey

DESIGN	RH	MODEL	RH
SCALE	1" = 10'	DATE	01/28/2021

ORIGINALLY FORMATTED FOR 22"x 34"
 ADJUST SCALE IF PRINTED AT ANY OTHER SIZE

A2

©2020 HARRISON architects :: All Rights Reserved

APPROVALS

SBS01 :: Peaches and Cream 2020

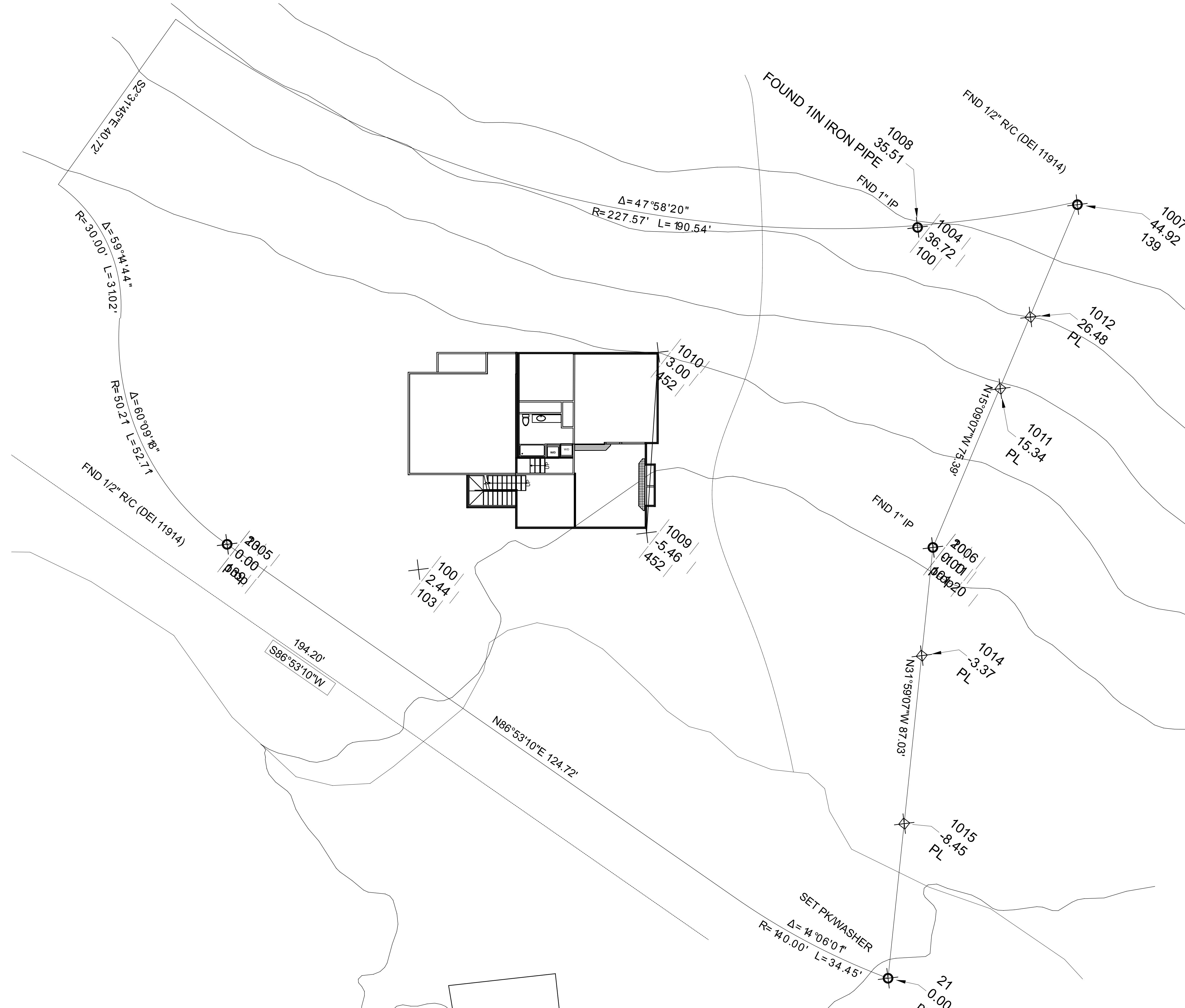

1 Boundary Survey
 A2 SCALE: 1" = 10'

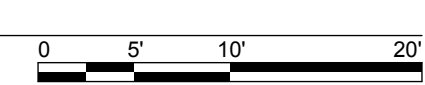

I:\Users\robharrison\Dropbox\HARRISON architects\Projects\Suzanne's House\1\Drawings & Models\1525_Ferncroft_v5.3_permit_response.dgn

NO.	ISSUE DATE
	Permit 12/10/2020
1	Response to Comments 01/28/2021

Peaches and Cream 2020
 4525 Ferncroft Road
 Mercer Island
 Washington 98040

Construction Documents
 6764
 REGISTERED ARCHITECT
 ROBERT HARRISON
 STATE OF WASHINGTON

HARRISON architects
 1133 18th Avenue, Suite B032
 Seattle, Washington 98122
 206.794.2738 mobile
 www.harrisonarchitects.com

Existing Plan

DESIGN	RH	MODEL	RH
SCALE	1/4" = 1'-0"	DATE	01/28/2021

ORIGINALLY FORMATTED FOR 22"x 34"
 ADJUST SCALE IF PRINTED AT ANY OTHER SIZE

A4

©2020 HARRISON architects :: All Rights Reserved

APPROVALS

SBS01 :: Peaches and Cream 2020

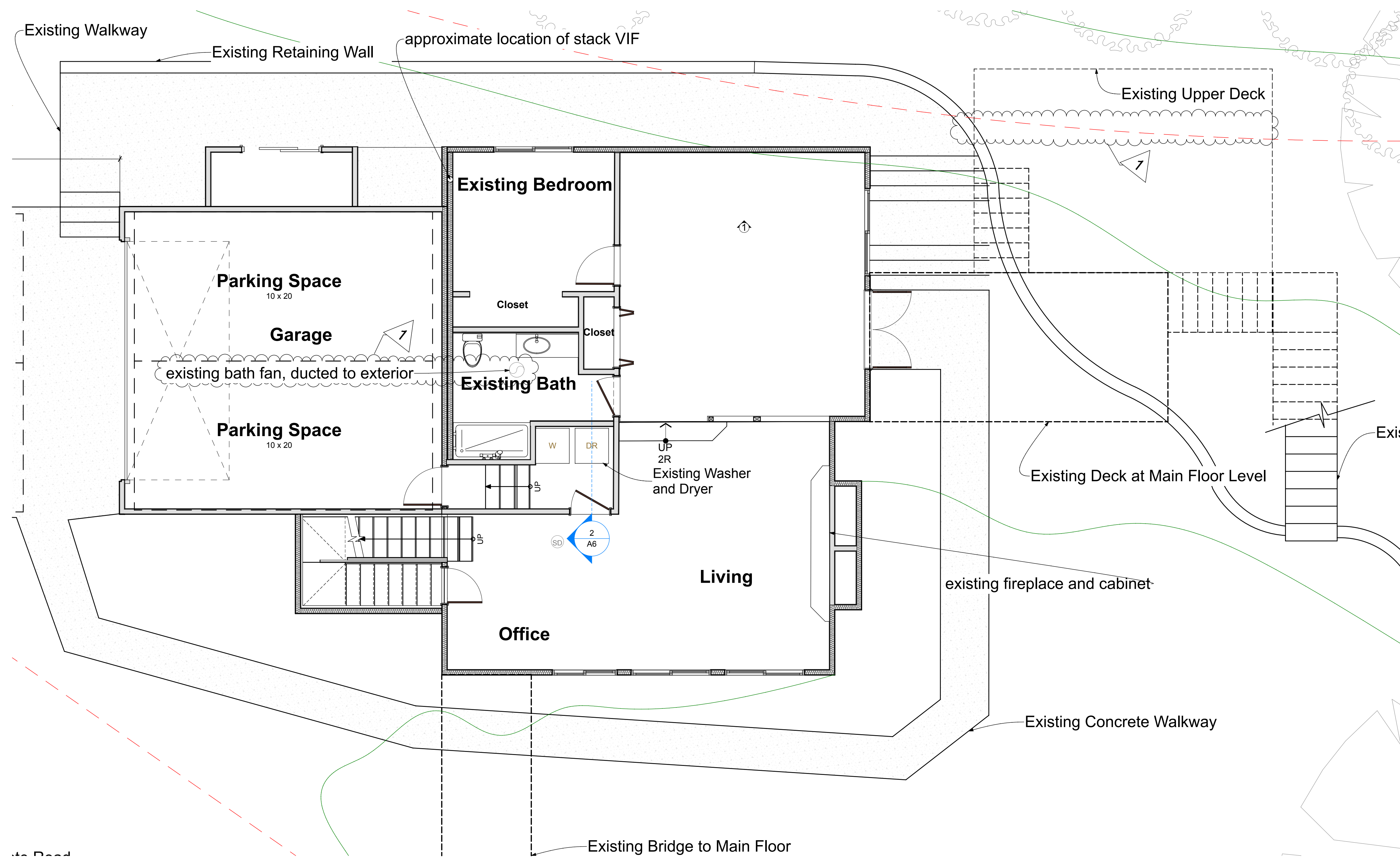

1 Existing Basement Plan
 SCALE: 1/4" = 1'-0"

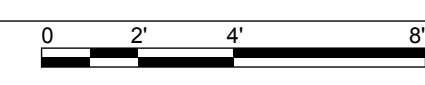

/Users/harrison/Dropbox/HARRISON architects /Projects /Suzanne's House /1 Drawings & Models/4525_Ferncroft_v5.3_permit_response.rvt

NO.	ISSUE DATE
	Permit 12/10/2020
1	Response to Comments 01/28/2021

Peaches and Cream 2020
 4525 Ferncroft Road
 Mercer Island
 Washington 98040

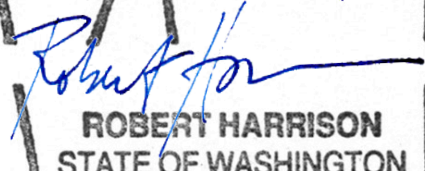
Construction Documents
 6764 REGISTERED ARCHITECT

 ROBERT HARRISON
 STATE OF WASHINGTON

HARRISON architects
 1133 18th Avenue, Suite B032
 Seattle, Washington 98122
 206.794.2738 mobile
 www.harrisonarchitects.com

Basement Plan with ADU

DESIGN	RH	MODEL	RH
SCALE	1/4" = 1'-0"	DATE	01/28/2021

ORIGINALLY FORMATTED FOR 22"x 34"
 ADJUST SCALE IF PRINTED AT ANY OTHER SIZE

A5

©2020 HARRISON architects - All Rights Reserved
 APPROVALS
 SBS01 :: Peaches and Cream 2020

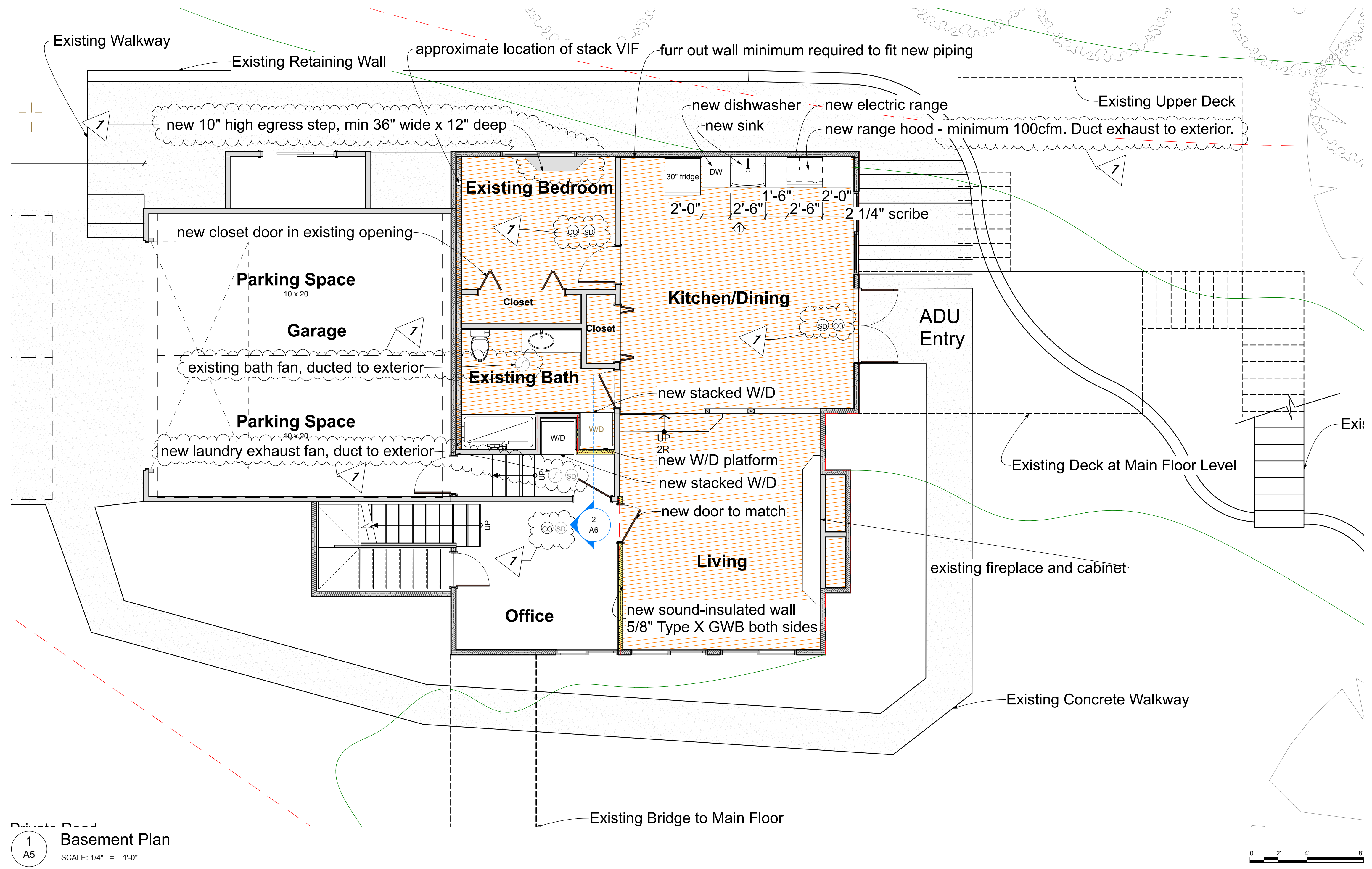

1
 A5
Basement Plan
 SCALE: 1/4" = 1'-0"

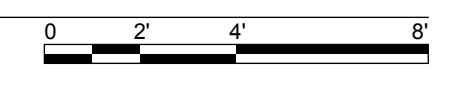

/Users/harrison/Dropbox/HARRISON architects /Projects /Suzanne's House /1 Drawings & Models/4525_Ferncroft_v5.3_permit_response.rvt

NO.	ISSUE DATE
	Permit 12/10/2020
1	Response to Comments 01/28/2021

Peaches and Cream 2020
 4525 Ferncroft Road
 Mercer Island
 Washington 98040

Construction Documents



HARRISON architects
 1133 18th Avenue, Suite B032
 Seattle, Washington 98122
 206.794.2738 mobile
 www.harrisonarchitects.com

Basement Interior Elevation & Section

DESIGN	RH	MODEL	RH
SCALE	1/2" = 1'-0", 1/2" = 1'-0"	DATE	01/28/2021
ORIGINALLY FORMATTED FOR 22"x 34" ADJUST SCALE IF PRINTED AT ANY OTHER SIZE			

A6

©2020 HARRISON architects - All Rights Reserved

APPROVALS

SBS01 :: Peaches and Cream 2020

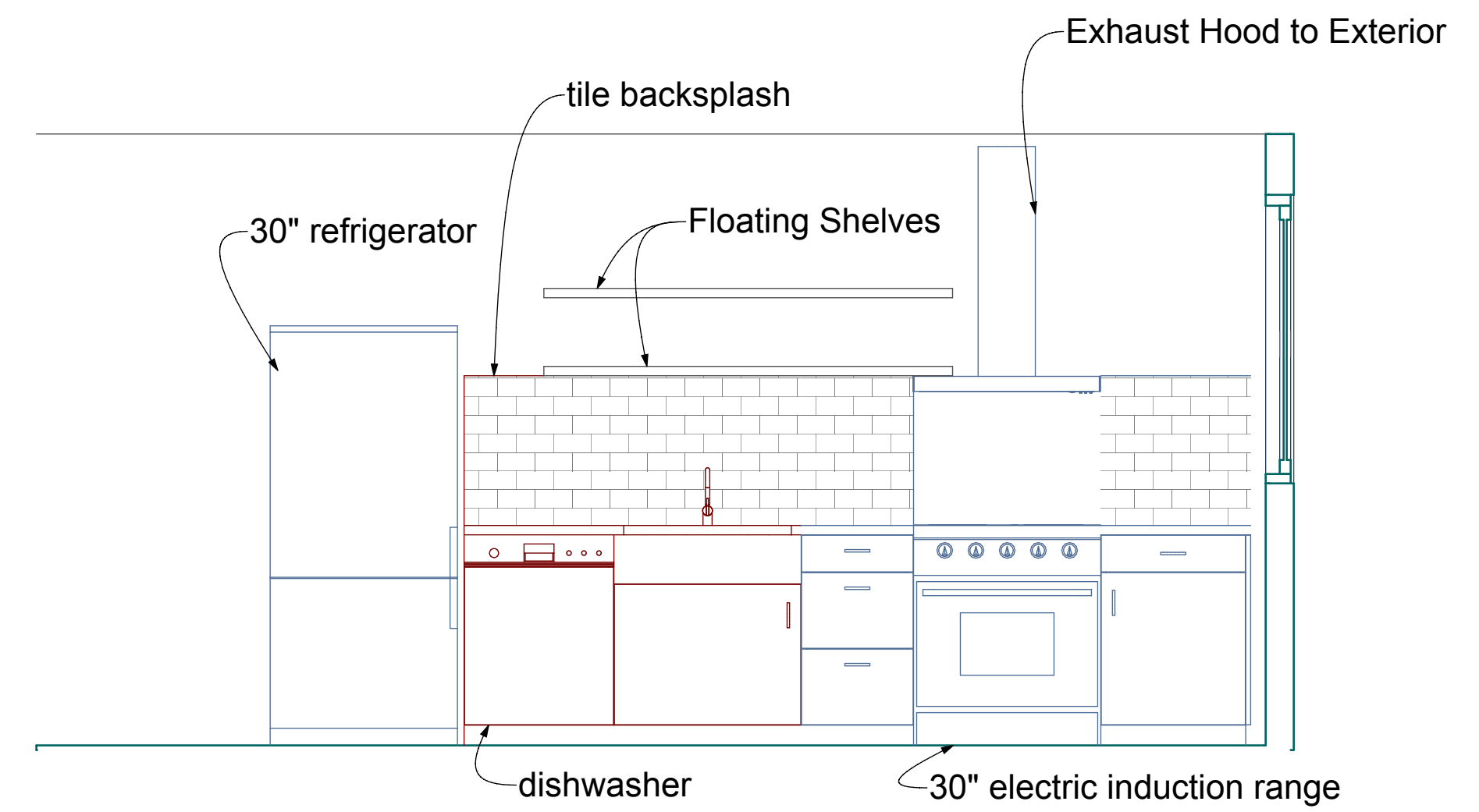

1 Kitchen Elevation
 SCALE: 1/2" = 1'-0"

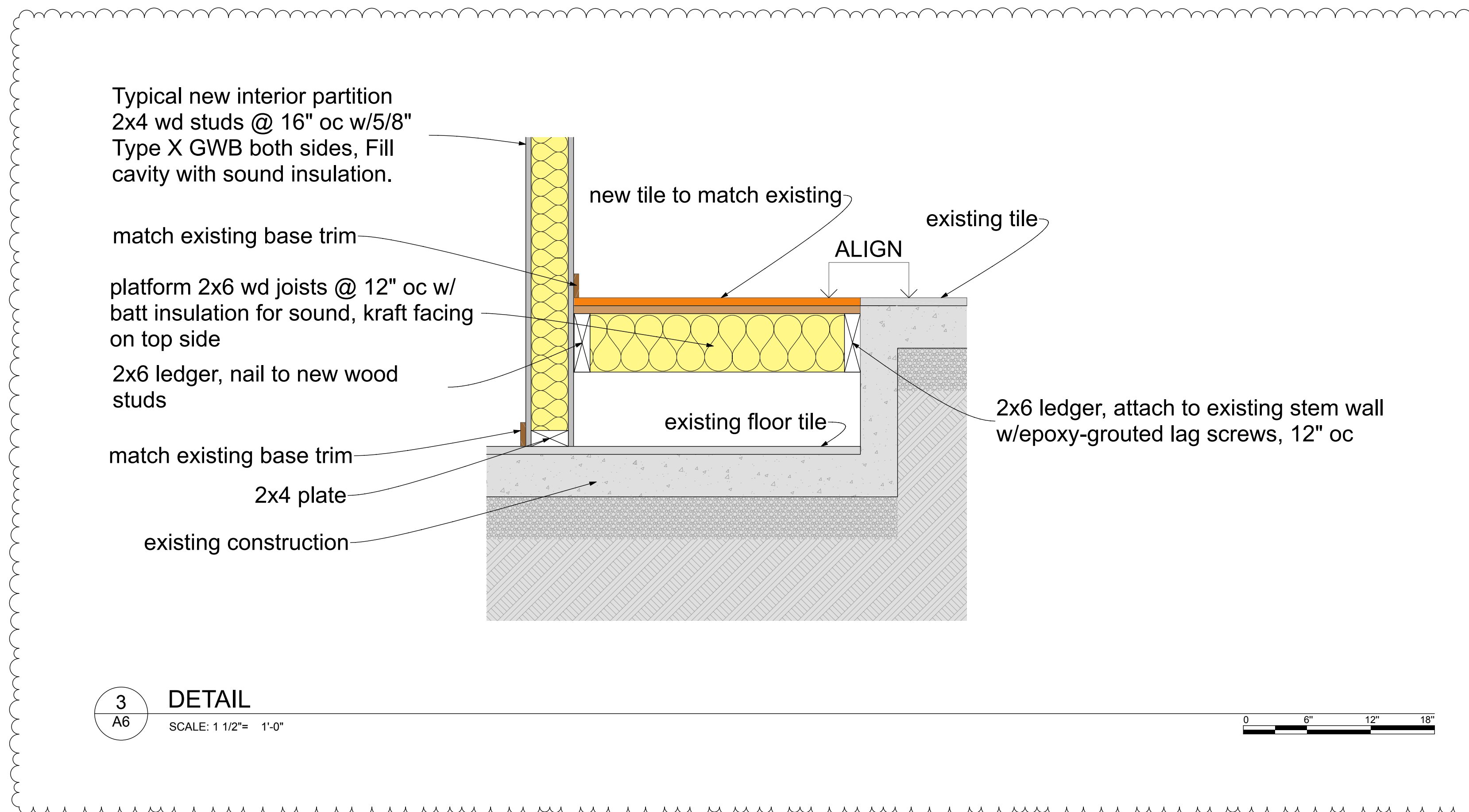
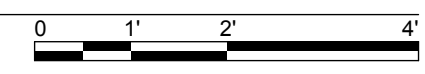

3 DETAIL
 SCALE: 1 1/2" = 1'-0"

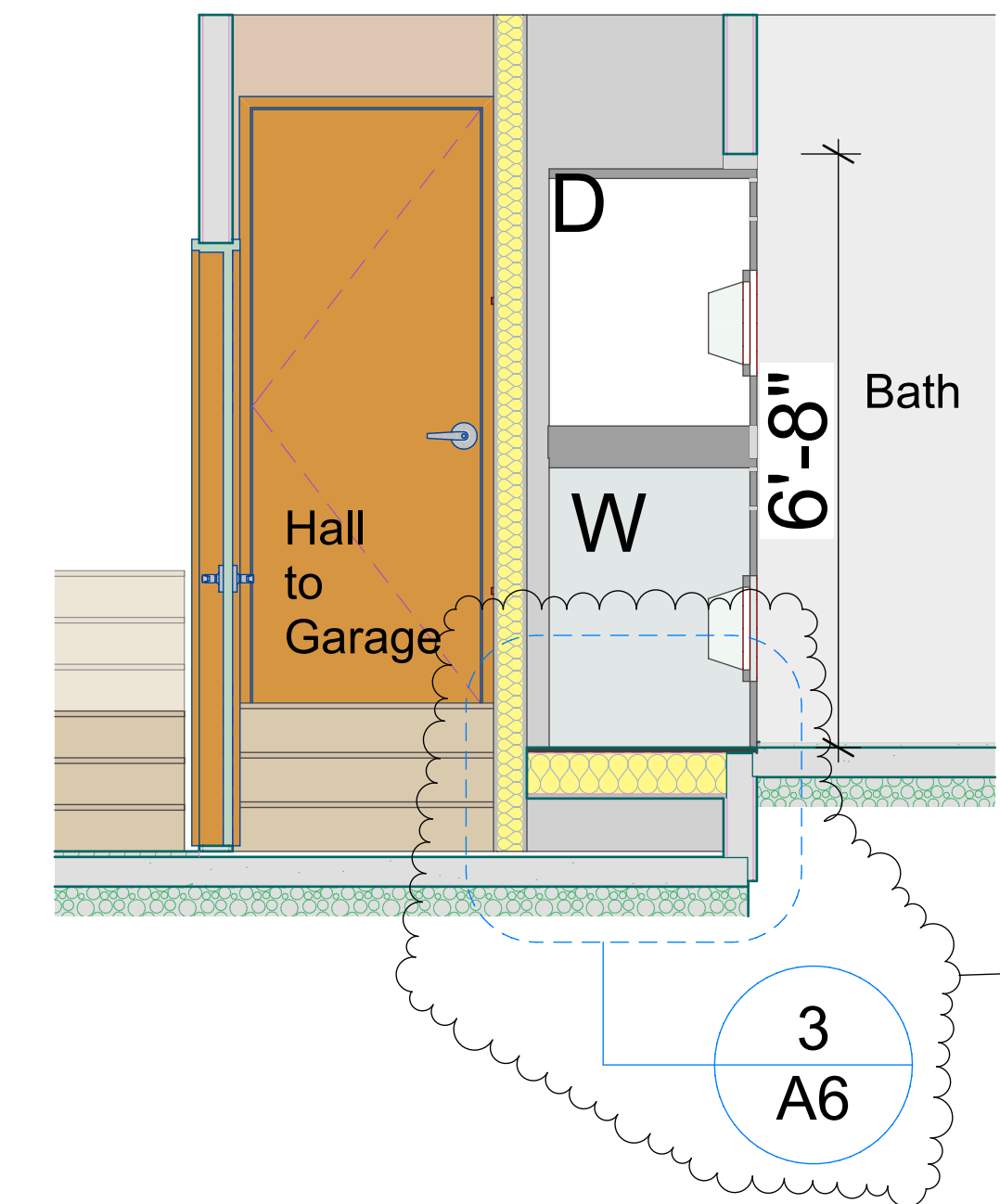
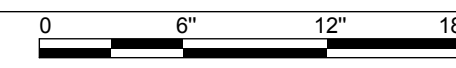

2 Section at Washers/Dryers (1)
 SCALE: 1/2" = 1'-0"

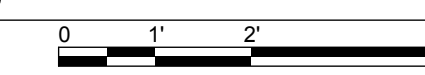

Verify height and width of stacked washer/dryers.

/Users/harrison/Dropbox/HARRISON architects /Projects/Suzanne's House /1 Drawings & Models/4525_Ferncroft_v3_permit_response.rvt

NO.	ISSUE DATE
	Permit 12/10/2020
1	Response to Comments 01/28/2021

Peaches and Cream 2020
 4525 Ferncroft Road
 Mercer Island
 Washington 98040

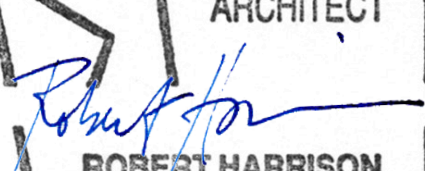
Construction Documents
 6764 REGISTERED ARCHITECT

 ROBERT HARRISON
 STATE OF WASHINGTON

HARRISON architects
 1133 18th Avenue, Suite B032
 Seattle, Washington 98122
 206.794.2738 mobile
 www.harrisonarchitects.com

Scan of Space Time Plan - Basement

DESIGN	RH	MODEL	RH
SCALE	1/4" = 1'-0"	DATE	01/28/2021

ORIGINALLY FORMATTED FOR 22"x 34" ADJUST SCALE IF PRINTED AT ANY OTHER SIZE

A7
 ©2020 HARRISON architects - All Rights Reserved
 APPROVALS

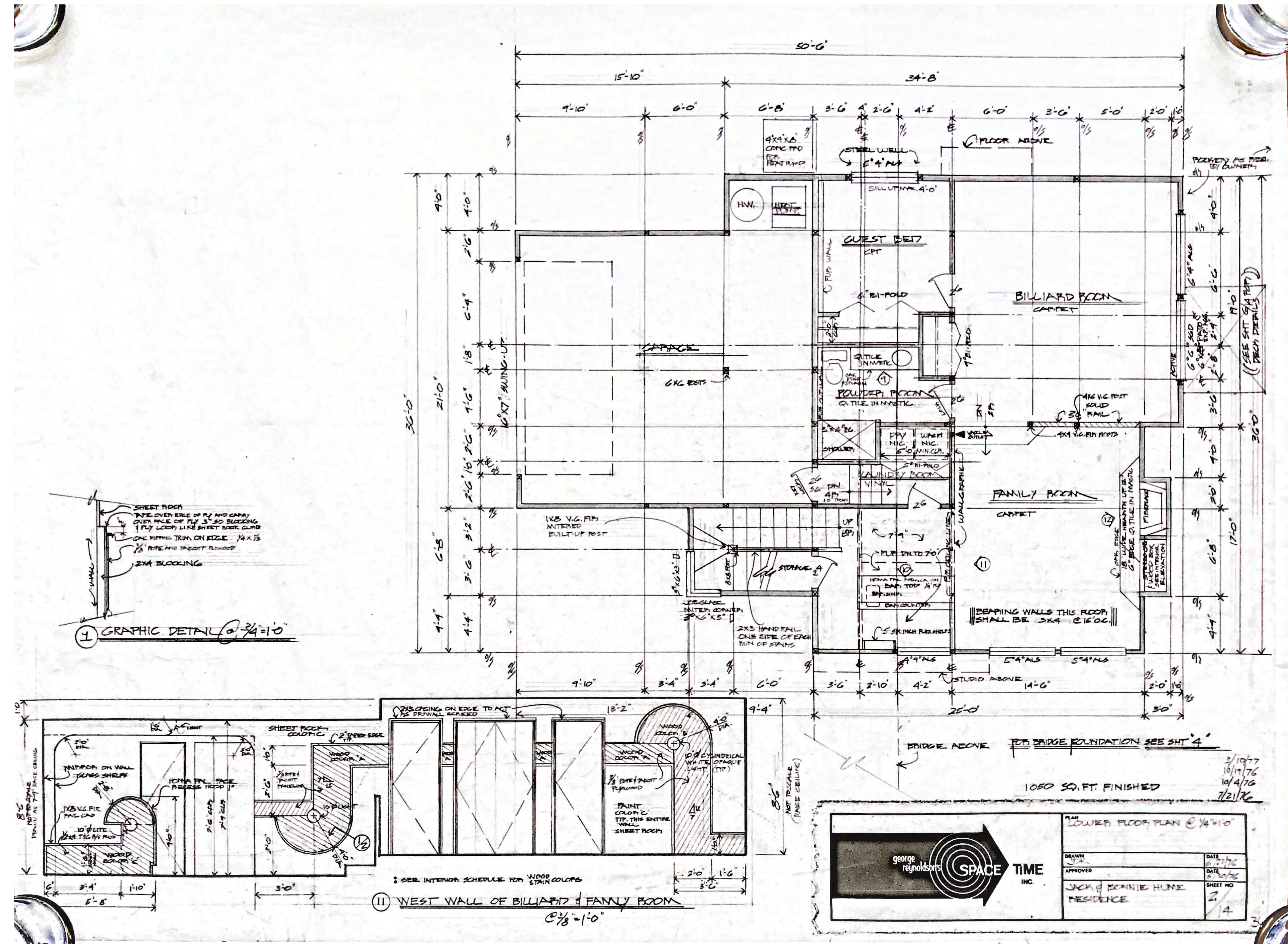

1 Scan of Space Time Plans - Lower Floor
 A7 SCALE: 1/4" = 1'-0"

FOR REFERENCE ONLY

I:\Users\harrison\Dropbox\HARRISON architects\Projects\Suzanne's House\11 Drawings & Models\1525_Ferncroft_v3.3_permit_response.dgn

NO.	ISSUE DATE
	Permit 12/10/2020
1	Response to Comments 01/28/2021

Peaches and Cream 2020
 4525 Ferncroft Road
 Mercer Island
 Washington 98040

Construction Documents
 6764 REGISTERED ARCHITECT
 ROBERT HARRISON
 STATE OF WASHINGTON

HARRISON architects
 1133 18th Avenue, Suite B032
 Seattle, Washington 98122
 206.794.2738 mobile
 www.harrisonarchitects.com

Scan of Space Time Plan - Main Floor

DESIGN	RH	MODEL	RH
SCALE	1/4" = 1'-0"	DATE	01/28/2021

ORIGINALLY FORMATTED FOR 22" x 34" ADJUST SCALE IF PRINTED AT ANY OTHER SIZE

A8
 ©2020 HARRISON architects - All Rights Reserved
 APPROVALS

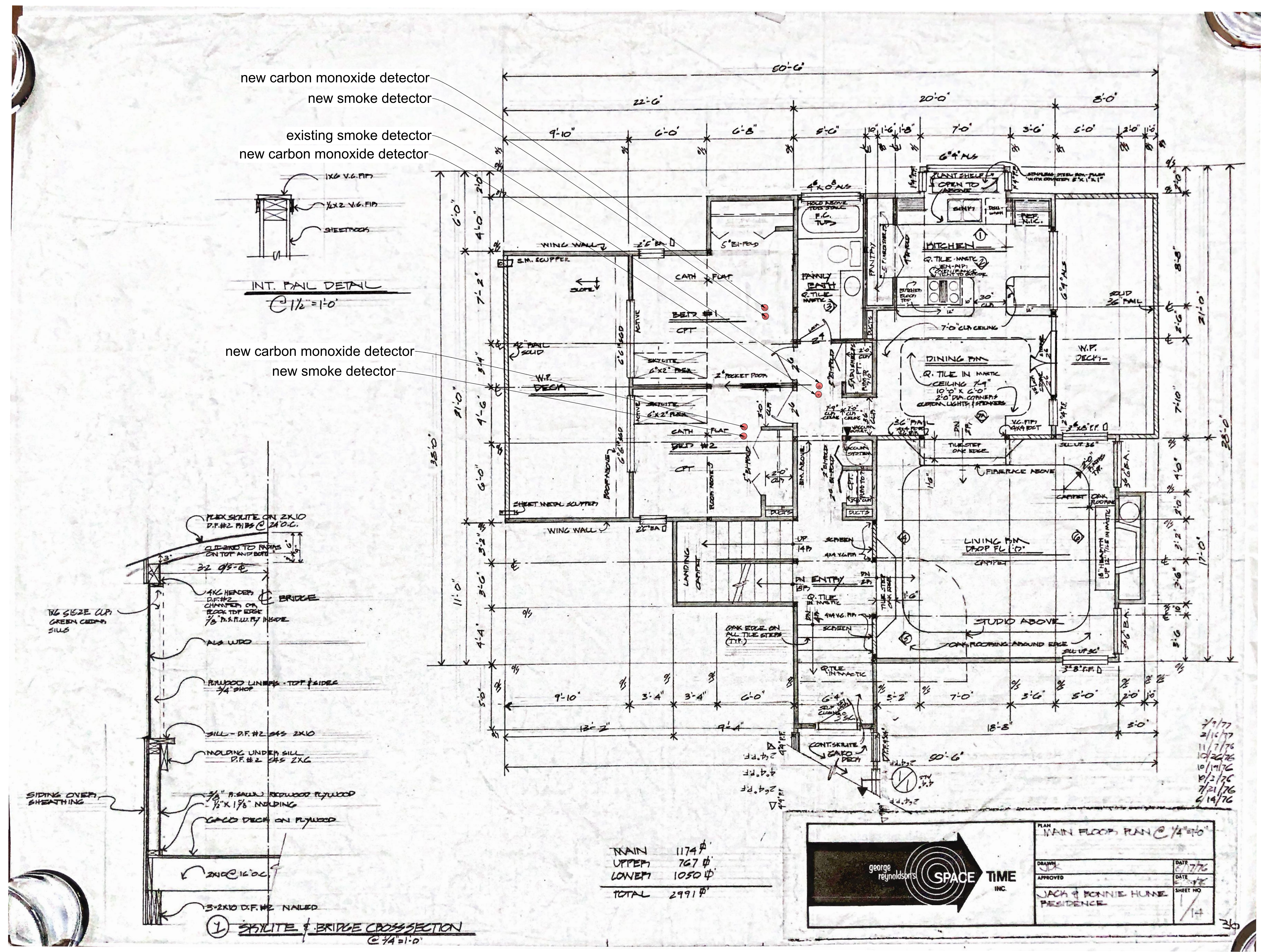

1 Scan of Space Time Plans - Main Floor
 A8 SCALE: 1/4" = 1'-0"

I:\Users\harrison\Dropbox\HARRISON architects\Projects\Suzanne's House\11 Drawings & Models\4525 Ferncroft_v3_3_permit_response.rvt

